

A method of mitigating tree blockage to bridges on a spillway

M.J. WEARING, CRM Rainwater Drainage Consultancy Ltd, Bolton, UK

R BAKER, CRM Rainwater Drainage Consultancy Ltd, Bolton, UK

I.C. CARTER, MWH, High Wycombe, UK

SYNOPSIS. On a wooded catchment there is a risk that fallen trees may be washed over the spill weir and trapped under bridges, which might result either in a loss of capacity and a potential overtopping of the dam or else a change in flow down the spillway and overtopping of the side walls. In the paper a trash barrier consisting of vertical poles placed upstream of the spill weir is described and results are presented from model tests showing the efficiency of the poles at trapping trees. It is concluded that the problem of tree blockage of a spillway can best be mitigated by the introduction of a double row of poles in front of the weir and that suitably placed poles would not affect the operation of the spillway.

INTRODUCTION

It is very common for access to be provided across the crest of an embankment dam with a bridge across the spillway. On many Pennine dams the engineers have built aesthetically pleasing multiple arch bridges some of which have very small waterways. On a wooded catchment these small arches present a safety hazard since a fallen tree washed under the bridge on a storm flood could result in total blockage of a waterway.

This could have two detrimental effects on the spillway performance. Firstly, the loss of capacity could result in the spillway weir drowning and rising reservoir levels causing the dam to overtop. Secondly, the change in flow pattern downstream of the bridge will alter flow depths and could accentuate cross-waves resulting in wall overtopping in different places to those expected under normal operation.

The paper describes model tests on rows of poles placed upstream of the spillway weir to trap large items of debris in the reservoir for removal after the flood has subsided.

ENSURING RESERVOIR SAFETY

PREVIOUS STUDIES

Previous work has been published on the use of rows of poles to trap trees upstream of hydraulic structures but most of these have concentrated on heavily wooded catchments where extreme numbers of floating trees could be expected during floods. The emphasis of those studies has thus been on the best way of trapping large quantities of debris without impeding flow.

The US Army Corps of Engineers manual (Wallerstein and Abt, 1997) on the subject contains examples of different types of structure that exist throughout USA and Europe, in particular the Treibholzfange scheme in the Bavarian Alps, where model tests showed that a row of poles in a downstream facing 'V' formation was very effective at trapping large quantities of debris. The manual also gives advice on mechanical trash racks that would self-clean during a storm event, although this would be an excessive solution for the issue of trapping trees during severe or extreme events, which was the key objective of the research discussed in this paper.

Godtland *et al* (1996) carried out model tests on trash barriers to trap trees and highlighted that branches on model trees are inherently stronger than on the prototype: a model tree will tend to trap where branches on the prototype would have broken allowing the tree to pass. Bearing this in mind the authors decided not to use model trees in this study that had foliage or a proliferation of small branches.

Godtland *et al* also noted that the behaviour of a single tree passing through a free waterway was quite different to a tree approaching a waterway that was already partially blocked. In a free waterway the tree aligns with the flow and passes through the structure but the alignment did not happen with partial blockage and thus an addition to the blockage was more likely forming a 'log jam'. This finding was also observed in the current study.

LABORATORY TESTS

Laboratory tests were performed using scale representatives of tree trunks, with or without branches. Five different configurations were used as shown on Figure 1. The trunk of the tree was made from 15mm dowel while branches were made from 8mm dowel. The simple log had a critical width of 15mm unless turned sideways. The log with one branch (ref. 1B) had a critical width of 60mm but it could rotate around a single pole. The log with two branches presented at an angle to each other (ref. 2B-3D) had a critical width of 80mm. The critical width for logs with two branches laid flat (ref. 2B) was 120mm and for logs with three branches (ref. 3B-3D) it was 80mm in any direction.

WEARING, BAKER & CARTER

The barrier poles were made from 6mm dowel and spaced at 50, 75 and 100mm. These model sizes could be scaled up to any size dependent upon the size of the object that was to be trapped, so for a 10m long log the model would simulate poles at 5, 7.5 and 10m spacing.

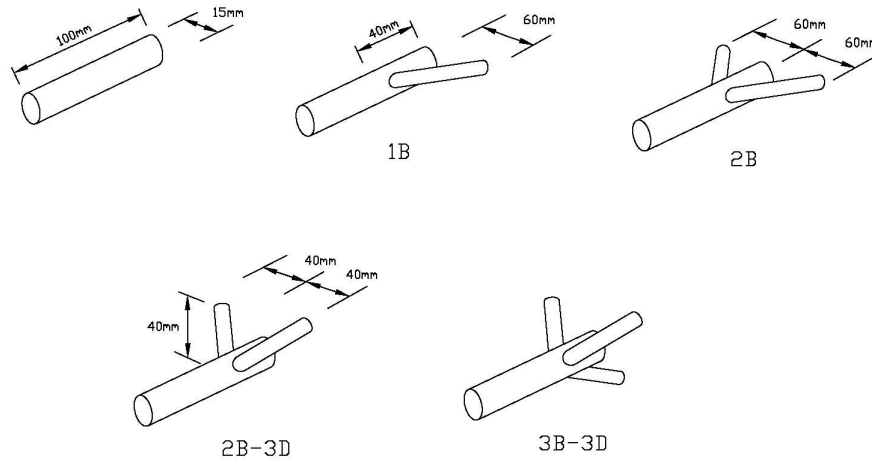

Figure 1 Configuration of the model trees

Model tests were performed on a 750mm wide weir in the side of a stilling box simulating the reservoir. Two flow rates were used, 15 l/s/m and 30 l/s/m, with a flow velocity through the poles of 0.25m/s and 0.3m/s respectively. This data would be scaled by Froude similarity and so for the 10m log described above this would be simulating flow rates of 15 m³/s/m and 30m³/s/m at velocities of 2.5 and 3m/s.

A single row of poles were set up in front of the weir and the model was operated at a constant flow rate with model trees being placed in the reservoir and allowed to flow freely towards the weir. The percentage of trees that were trapped was noted and is recorded in Table 1. Trapped trees were removed from the model so that a ‘log jam’ could not form.

Table 1 – Percentage of trees trapped by a single row of poles

Spacing (mm)	Flow (l/s/m)	Tree shape				
		Log	1B	2B-3D	2B	3B-3D
100	15	10.0	10.0	30.0	83.3	80.0
	30	0	15.3	28.6	53.3	50.0
75	15	9.1	53.8	92.9	100	100
	30	8.3	60.0	86.7	100	100
50	15	50.0	100	100	100	100
	30	29.4	100	100	100	100

ENSURING RESERVOIR SAFETY

As the tree approached the row of poles the main 'trunk' section was observed to align with the flow and tended to pass through the middle between a pair of poles, it was therefore quite unlikely that the simple log shaped tree would become trapped. However, it is probable that this same flow orientation would happen through a bridge and thus the simple log would be less likely to become trapped and present a hazard.

For the 100mm spacing the 1B and 2B-3D shaped logs had a critical width less than the gap and thus were more likely to pass through than become trapped. Those that were trapped normally became lodged with the pole against the joint between the log and the branch (Photograph 1) although other wedge positions were possible (Photographs 2 and 3). The 2B shaped log could also become wedged between a pair of poles held by both branches (Photograph 4). The 3B-3D tree was a more complex shape and it was observed that this could become trapped by branches trailing under water and becoming wedged on the bed at the lower flow. In all cases increasing flow rate meant that more trees passed through the row of poles.



Photograph 1 – A 2B type log trapped on a single pole.



Photograph 2 – A 2B-3D type log trapped between two poles.



Photograph 3 – A type 1B log trapped on a pair of poles.



Photograph 4 – A type 2B log trapped between two poles.

WEARING, BAKER & CARTER

As could reasonably be expected, the efficiency of the operation was improved by reducing the pole spacing relative to the size of the tree that was to be trapped. For example, a 2B type tree could not physically pass through a spacing less than 75mm. At 50mm spacing, which was half the length of the object being trapped and less than the critical width of all but the straight log, 100% of all trees and some of the straight logs were trapped.

If a log jam was allowed to form (Photograph 5) then a greater trapping efficiency than that noted in Table 1 was achieved and there was some build up of water level behind the log jam.

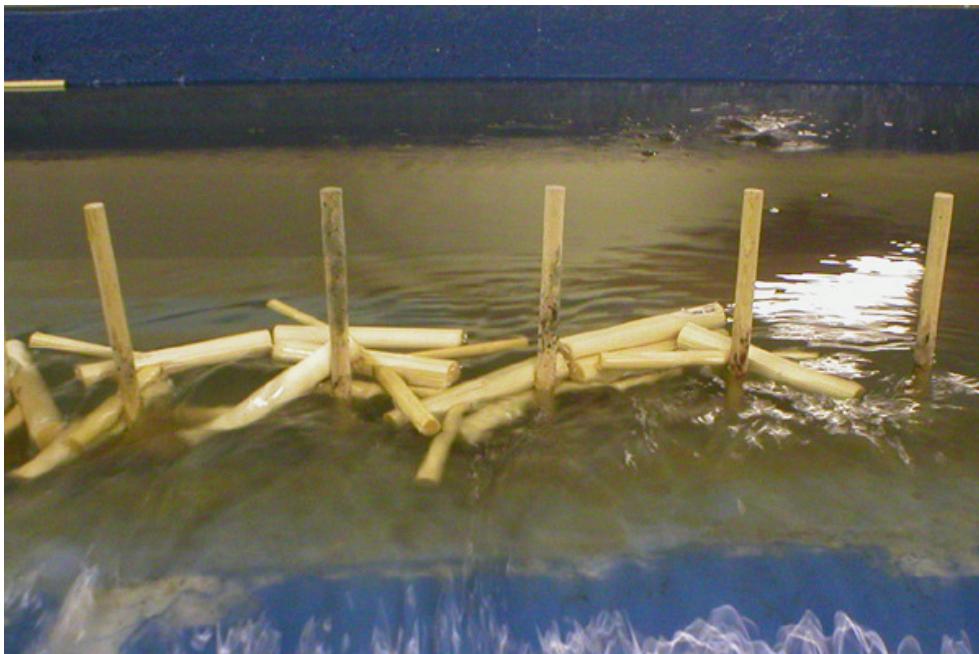

Photograph 5 – Log jam

The experiments continued with the poles in two rows spaced so that a pole on the second row lay exactly in the middle of two poles on the first row. The two rows were spaced apart so that the triangular distance from the upstream pole to the downstream pole was equal to the pole spacing, thus any three adjacent poles formed the corners of an equilateral triangle.

This arrangement was found to be much more efficient, as shown in Table 2. The logs continued to align with the flow to pass between the middle of two poles on the first row, which caused them to impact onto the pole in the second row. Sometimes the log bounced off or rotated and passed through but normally it rotated and trapped across the two rows of poles (Photograph 6 and 7).

ENSURING RESERVOIR SAFETY

Table 2 – percentage of trees trapped by a double row of poles

Spacing (mm)	Flow (l/s)	Tree shape				
		Log	1B	2B-3D	2B	3B-3D
100	15	33.3	38.9	81.3	100	100
	30	20.0	16.6	71.4	100	100
75	15	50.0	100	100	100	100
	30	0	100	100	100	100
50	15	80.0	100	100	100	100
	30	78.6	100	100	100	100

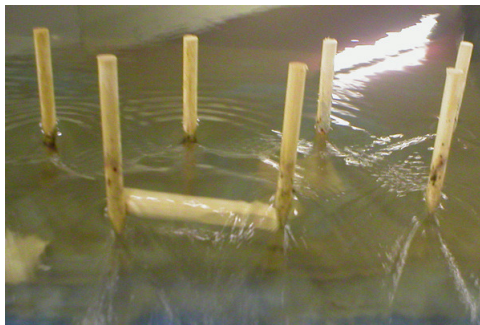

Photograph 6 - Log trapped across two poles on the second row

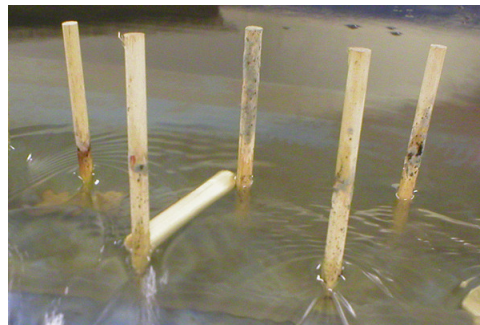

Photograph 7 - Log trapped between the two rows of poles

When installing poles of this nature the designer should carry out structural checks to ensure that the poles have adequate foundation to resist the turning moment generated by the head of water that could build up behind a log jam.

Many old earth embankment dams in the UK have thin upstream clay blankets that were either part of the original construction or else were added later in an attempt to make the dam watertight. Therefore, if barrier poles are to be installed at the weir approach, then care should be taken to ensure that the integrity of any waterproofing element directly beneath the surface is not compromised. Failure to do so could lead to leakage, which may be difficult to detect.

Poles will also collect quantities of smaller items of debris during normal operation and a suitable regime should be devised for clearing this debris, possibly during summer months when reservoir levels are low.

WEARING, BAKER & CARTER

CONCLUSIONS

Model tests have shown that a tree trunk will tend to align itself with the flow and pass between a pair of poles designed to trap it: the higher the flow rate and hence velocity, then the greater the number of trees that will pass through a row of poles.

A log can hit a pole and rotate to pass through the gap. As could reasonably be expected the smaller the gap size relative to the tree the more chance there is of trapping it. If the gap is half the length of the tree and less than the critical width of the branches, then there is complete certainty that the tree will be trapped.

If a second row of poles is placed downstream, then a log passing through the gap in the first row of poles is likely to hit a pole in the second row, rotate and become trapped. With two rows of poles, a 100 percent trap can be achieved with a spacing three quarters of the length of the tree even if the critical width is slightly less than the pole spacing.

REFERENCES.

- Godtland K, Johnsson N and Cederström M (1996) *Floating debris and dam safety under extreme floods*. Proceedings of the European Symposium on Repair and Upgrading of Dams, Stockholm, pp 374-382.
- Wallerstein C.R and Abt S.R (1997) *Debris Control at Hydraulic Structures in Selected Areas of the United States and Europe*. US Army Corps of Engineers Waterways Experimental Station, Contract Report CHL-97-4.